



Searching for a New Balance

SM-100 Series Scale Printer

RETAIL PRODUCTS

- State of the art communications with TCP/IP built in!
- Flexible label formatting with full graphic capability. Image printed on label with .bmp files
- Simple and quick changing between labels using the removable cassette
- Capable of full ingredients and cooking instructions
- Meets Canadian nutritional label requirements



SM-100 B



SM-100 H



SM-100 P

THE DIGI SM-100 BENCH

The SM-100 is ready for today's needs and tomorrow. Fully capable of ingredients and nutrients the scale will grow with you.

PACKED ON
06-JN-29

BEST BEFORE
06-JL-04

UNIT PRICE
\$1.00/kg

NET WEIGHT
5.000 kg

Nutrition Facts	
Valeur nutritive	
Per 125 mL (87 g)	
Pour 125 mL (87 g)	
Amount	% Daily Value
Teneur	% valeur quotidienne
Calories / Calories	80
Fat / Lipides	0.5 g 1%
Saturated / saturés	0.0 g 0%
+ Trans / trans	0.0 g
Cholesterol / Cholestérol	0 mg
Sodium / Sodium	0 mg 0%
Carbohydrate / Glucides	18 g 6%
Fibre / Fibres	2 g 8%
Sugars / Sucres	2 g
Protein / Protéines	3.0 g
Vitamine A / Vitamine A	2%
Vitamine C / Vitamine C	10%
Calcium / Calcium	10%
Iron / Fer	2%



Total Price
\$5.00

DIGI CANADA INC

Thank you to our loyal customers for their continued support



SM-100 Series Scale Printer

The Preferred Choice for Service Scale Printer

Specifications

Model	SM-100 P (Pole Type) SM-100 B (Bench Type) SM-100 H (Hanging Type)
Capacity	6 Kg (1 - 2 g increment) 15 Kg (2 - 5 g increment) 30 Kg (10g increment) 30 lb (.01lb increment)
Memory capacity	2 MB (standard)
Display Resolution	1 / 3,000 (dual range)
Display	All types - Operator: 32 x 202 full dot matrix green LCD display - Customer: 32 x 202 full dot matrix green LCD display
	Tare Weight: 4 Digits
	Weight: 5 Digits
	Unit Price: 6 Digits
	Total Price: 7 Digits
Printing	Paper Width: Maximum 60 mm (label) - 56 mm printable 40 or 60 mm (receipt)
	Speed: 80 mm / second (label) 105 mm / second (receipt)
	Label Size: Length: 28 - 220mm Width: 30 - 56mm
Power Source	AC 110 / Volts (50 / 60 Hz)
Operating Temperature	-10 °C to +40 °C
Humidity	15 % to 85 % RH
Interface	Standard: Ethernet

RETAIL PRODUCTS

SM-100 P

SM-100 B

SM-100 H

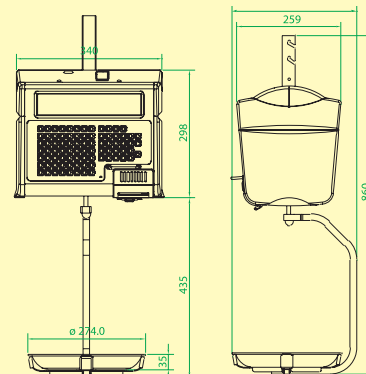
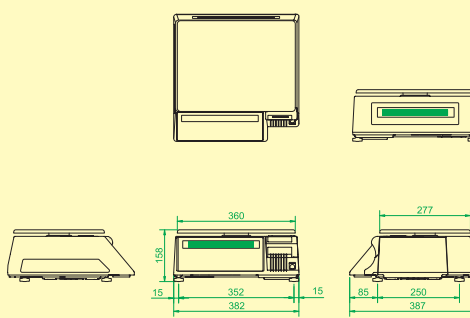
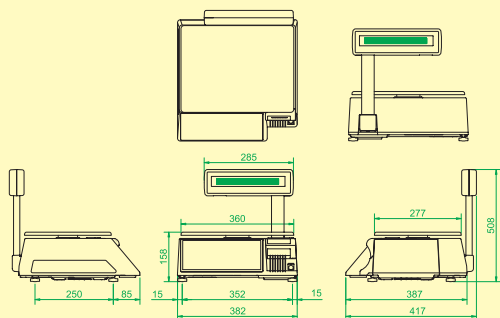

Thank you to our loyal customers for their continued support